

Job Information <i>Fill out project details for this product below</i>			
Project		Location	
Contact		Date	
Product Number		Fixture Type	

A dimmer that uses pulse width modulation, controlled by 0-10 VDC switches. Offers smooth dimming with no flickering. A great choice for commercial and residential applications.



KEY FEATURES & BENEFITS

- Easy installation
- UL Class 2 certified
- IP66 rated
- Short circuit protection
- Works for 12 V and 24 V applications

OVERVIEW

FRONT VIEW

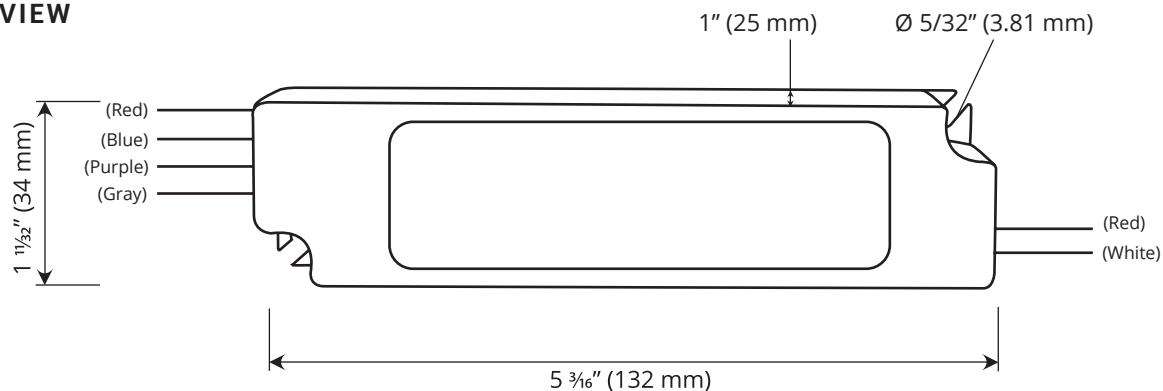

SPECIFICATIONS

PHYSICAL

Part Number	970001
Operating Temperature	-40 °C (-40 °F) ~ +60 °C (+140 °F)
Ambient Temperature	-40 °C (-40 °F) ~ +80 °C (+176 °F)
Lifespan	50 000+ hours
Dimensions	5 3/16" (132 mm) L x 1 11/32" (34 mm) W x 1" (25 mm) D

ELECTRICAL

Input Voltage	12 VDC • 24 VDC
Output Voltage	12 VDC • 24 VDC
Rated Wattage	Max. 60 W • Max. 98.4 W
Output Current	< 5 A • < 4.1 A
Dimming Control	0 - 10 V
Efficiency	> 98% typical
Certifications	UL listed

- The light output of the LEDs operated by the Dimmable Driver is controlled by DC voltage applied to the control input leads (0-10 V DIM purple and gray)
- The control device must be capable of accepting, or sinking, the DC current flow from the driver. The maximum under any condition is 500 microamps per driver
- The control terminals of the driver are isolated from the power lines and are suitable for use as Class 2 terminals. As many drivers as desired for use with the particular control device may be connected in parallel in a bus configuration. The length of the bus, the wire size of the bus and the number of drivers connected on the bus must be configured so that the DC voltage drop as a function of the resistance of the wire and the control current flowing does not exceed 0.2 volts for dimming controls. For controls used as a minimum / maximum, or hi-lo 2-level application, the maximum DC voltage drop must not exceed 0.5 volt
- If the control bus is opened, or if the control device internally opens the control bus under some conditions, the voltage on the control bus will then be a function of the ballast, which is 10 ± 0.5 volts. Maximum light output will be delivered under this condition
- If the control bus is shorted either by a mechanical switch in the control or by the circuitry of the control device, or inadvertently in the wiring, the current on the control bus will be 500 microamps per driver maximum. All drivers on the control bus will then operate at minimum light level
- As can be determined from the two above items, simple two-level operation of the driver can be achieved by proper usage and application of a simple open / close switch on the control bus with maximum light being achieved when the switch is open and minimum light when the switch is closed
- The driver is intended for use with control voltages between 0 and 10 VDC. The control equipment must not impose a voltage greater than 11.0 - volt peak maximum on the driver control terminals
- The DC control voltage should have a maximum peak to peak ripple (low and high frequency ripple) not exceeding 10% of the average VDC.
- Short-term transient voltage of the control devices must not exceed 14 volts. Control equipment intended to control more than one driver must be capable of sinking the current supplied to the control bus by the maximum number of drivers specified for the control device. At any given level setting it must maintain control bus voltage constant within a range of $\pm 5\%$ as the number of drivers connected to the control bus varies from a minimum of one driver up to the maximum number specified for the control device
- Drivers of various input ratings (120 V, 230 V, 277 V) may be used in this control system
- Since the control bus is Class II wiring, all control devices that are connected to the power line must have proper isolation between the power line and the control leads. Any control devices that are connected to the power line must have UL approval / recognition as Class II equipment

WIRING

WIRING EXAMPLE

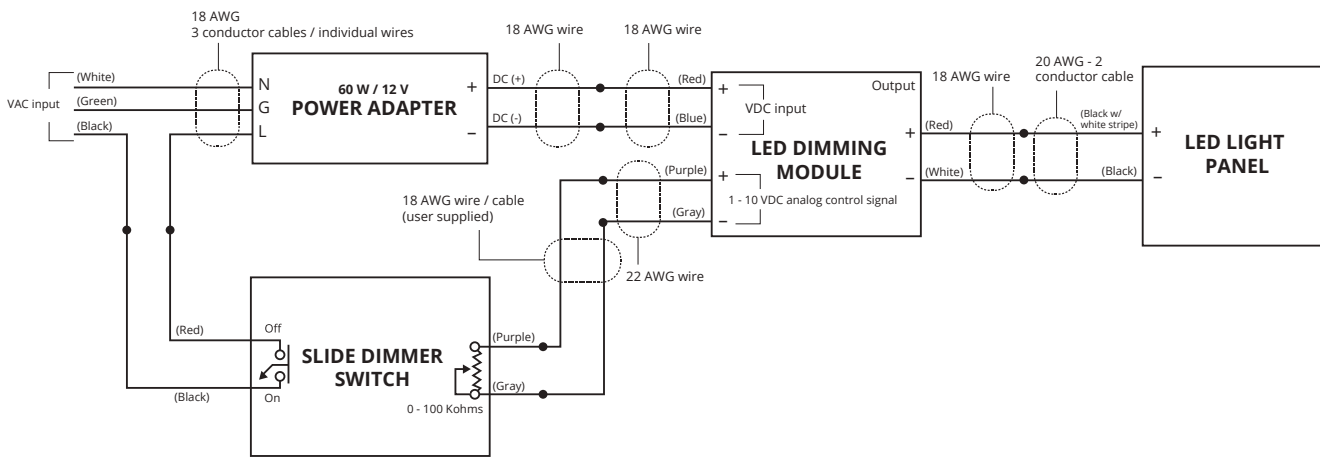

ORDER INFORMATION

Product #	Voltage	Wattage
970001	12 - 12V DC 24 - 24V DC	060 60 W 098 98.4 W

EXAMPLE

970001-12-060

The specification number immediately above can be deconstructed as follows:

- 12V 60W Dimming Module; Voltage-12V; Wattage-60W